

# EXPLORATIONS

Engineering Solutions to Problems of National Significance

WINTER 2004

Coordinated Navy/Air Force  
Inertial Sensor Development Programs

Draper Leads Modernizing of the Navy's  
Trident MK6 Guidance System

Designing an Enhanced Ground Test  
Capability to Simulate Missile Test Flights

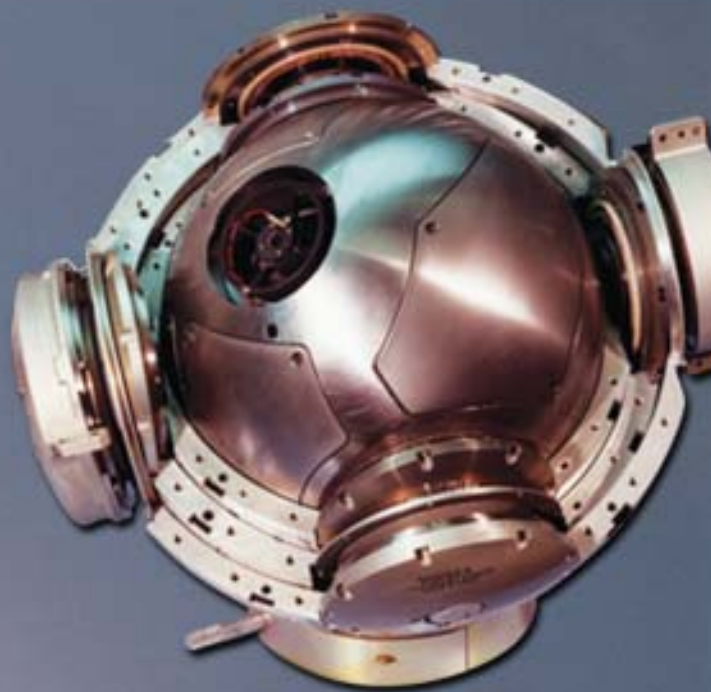

**DRAPER**  
LABORATORY 

## TABLE OF CONTENTS

Evolving Missions for the 21 <sup>st</sup> Century: Draper's Strategic Systems Are Leading the Way	1
Coordinated Navy/Air Force Inertial Sensor Development Programs	2
Draper Leads Modernizing of the Navy's Trident MK6 Guidance System	4
Designing an Enhanced Ground Test Capability to Simulate Missile Test Flights	6
2003 Distinguished Performance Awards Presented	7
Board and Corporation Gain New Members	8
Technology Exposition 2003 Shows Strength, Breadth	9

*Explorations* is produced by Draper Laboratory's Office of Public and Employee Communications:

617-258-2605  
communications@draper.com  
www.draper.com

*Editorial Staff:*

Kathleen Granchelli, Director  
Allison Looney  
Amy Schwenker

*Photography:*

Jay Couturier  
Drew Crete

*Design:*

Amy Schwenker  
Pamela Toomey

### 2004 CHARLES STARK DRAPER PRIZE AWARDED TO DEVELOPERS OF THE ALTO

The team that led the development of the first practical networked personal computer (the Alto) are the winners of the 2004 Charles Stark Draper Prize. The winners were announced at a press conference in Washington, D.C., on Feb. 24, and the prize was presented at a ceremony later that evening. Alan Kay, Butler Lampson, Robert Taylor, and Charles Thacker share the \$500,000 award, which is administered by the National Academy of Engineering. More information is available at [www.nae.edu](http://www.nae.edu).

Questions about the projects presented in this publication or about Draper's engineering capabilities should be directed to the Business Development Office; they can be e-mailed to [busdev@draper.com](mailto:busdev@draper.com).

The views and opinions contained in this publication are those of The Charles Stark Draper Laboratory, Inc., and should not be construed as reflecting those of the Department of Defense or other office or agency of the U.S. Government.

Copyright © 2004 by The Charles Stark Draper Laboratory, Inc. All rights reserved.

Photo by Cable Risdon for NAE



Left to right: George M.C. Fisher (NAE Chairman), Vince Vitto (Draper President), Kurt Taylor (son of winner Robert Taylor), Charles Thacker, Alan Kay, Butler Lampson, Aaron Cohen (2004 Draper Prize Selection Committee Chair), and Wm. Wulf (NAE President).

# EVOLVING MISSIONS FOR THE 21<sup>ST</sup> CENTURY: DRAPER'S STRATEGIC SYSTEMS ARE LEADING THE WAY



Draper Laboratory has been a leader in the design and development of strategic-grade inertial guidance systems, components, and technology since the 1950s. We have been the design agent for all U.S. Navy strategic guidance systems since Polaris and for the Air Force Peacekeeper missile guidance system. In addition, Draper has designed or helped develop radiation-hard, highly reliable inertial sensors for all of the U.S. strategic systems. This is a legacy of which we are proud and is the base from which we look to the future.

The recently completed Department of Defense Nuclear Posture Review (NPR) defined a new triad with an expanded strategic mission set. Of most significance to Draper was the addition of prompt, conventional global strike. The NPR also supported life extension programs for the existing Trident II (D5) and Minuteman III systems to ensure the traditional nuclear deterrence mission will be supported well into the 21<sup>st</sup> century. The combination of supporting new conventional missions and service life extension of legacy systems while balancing other program priorities, such as fleet and factory support, provides Draper with an exciting challenge for the next decade.

Among the efforts that Draper will continue as it undertakes new activities is support to both the Navy and Air Force in the testing and design of current and future strategic reentry vehicles—the payload portion of the missile that

freefalls to the target after the boosters and guidance systems set it on the correct trajectory. The Lab has developed instrumentation to gather flight test data to accurately measure the vehicles' behavior within the harsh reentry environment and has modified GPS receivers to operate during demanding reentry conditions.

In the past year, our historic role as design agent for the U.S. Navy has expanded to that of Program and Systems Integrator for the entire Navy Strategic Guidance Program. We now have programmatic responsibility for the total life cycle, which includes design, development, production, repair, deployment, and retirement.

This issue of *Explorations* features the major strategic programs Draper currently supports: the Navy's Trident II (D5) MK6 Missile Guidance Service Life Extension (LE) effort, the Enhanced Ground Test (EGT) program, and the coordinated Navy/Air Force inertial sensor development programs.

Aside from support of the deployed fleet, the Trident LE is our highest priority and most technically complex program. The objective is to develop a guidance system design that corrects all known aging and failure mechanisms, increases mission flexibility, and lowers life cycle costs while maintaining all of the currently defined interfaces between the guidance subsystems and the rest of the Trident missile. Draper also expects to lower MK6 life extension costs and reduce program risk

through the use of an EGT capability, a nondestructive simulated missile flight environment to validate guidance hardware and designs and to perform reliability and accuracy assessment tests. The coordinated Navy/Air Force inertial sensor development programs seek to develop small, solid-state, multi-mission inertial guidance systems as affordable solutions for existing and future missile and reentry guidance applications.

Successful execution of these programs is critical not only to U.S. strategic goals, but also to the growth of new technology concurrent with long-term sustainment of critical skills. These programs simultaneously will challenge the existing guidance team and train the next generation of engineers who will provide stewardship of the program for decades to come.

Draper Laboratory's heritage of providing leadership, technical knowledge, and operational support to the nation's strategic programs has a sound future. We remain focused on maintaining the Navy and Air Force deployed missile guidance and reentry systems as we develop technology and program options for expanding strategic missions. I hope you find this issue of *Explorations* interesting and informative.

— John Stillwell  
Principal Director, Strategic Systems

# COORDINATED NAVY/AIR FORCE INERTIAL SENSOR DEVELOPMENT PROGRAMS

The ICBM and submarine-launched strategic missiles developed over the past 50 years have employed successive generations of increasingly accurate inertial guidance systems. These systems are built around a core of inertial instrument sensors that measure missile acceleration (accelerometers) and rotations (gyros). These measurements allow the guidance system computer to solve the equations that describe Newton's laws of motion and thus compute the missile's position, velocity, and orientation. These in turn can be used to guide the missile to its intended target.

Draper's technical capabilities are being applied to the development of advanced solid-state, strategic-grade inertial instruments (both gyros and accelerometers) for the Navy and Air Force. Compared to the electromechanical accelerometers and gyros in use today, these new sensors promise to be smaller, more affordable, and more reliable. For example, the U.S. strategic missile arsenal currently relies on variants of the Pendulous Integrating Gyro Accelerometer (PIGA) to meet the high performance, radiation-hard requirements of the weapon system. However, the venerable and mature PIGA is a complex accelerometer having more than two hundred precisely machined, small moving parts—a life cycle cost drawback that has motivated a search for a more modern, solid-state, strategic-grade accelerometer.

Draper currently is working with industry on several new classes of gyro and accelerometer technologies for strategic missile applications. These include working with Honeywell on the interferometric fiber-optic gyro (IFOG) and Northrop Grumman on the hemispherical resonating gyro (HRG), as well as several advanced accelerometer concepts. The following sections discuss two of the recent solid-state strategic accelerometer developments at Draper: the Silicon Oscillating Accelerometer (SOA) and the Flexured Mass Accelerometer (FMA). Both accelerometers are in the prototype stage, and both are demonstrating strategic-grade performance in a laboratory environment. In the upcoming years, these

instruments will be refined further and undergo testing in missile flight environments and will be subjected to radiation testing representative of a nuclear hostile environment. These radiation tests are the ultimate hurdle for any instrument considered for a nuclear strategic application. It is the radiation-hard aspect of the instrument design that, in large measure, distinguishes this class of inertial instrument from all others.

where acceleration is sensed as a change in the resonant frequency of beam oscillators under the inertial loading of a proof mass. The figure below shows a schematic illustrating how the instrument measures acceleration. Two opposing tuning forks (beams) are connected to a large proof mass. The beams are also rigidly attached to a substrate at certain points but are free to resonate and are driven to do so at their natural frequency by small motors.

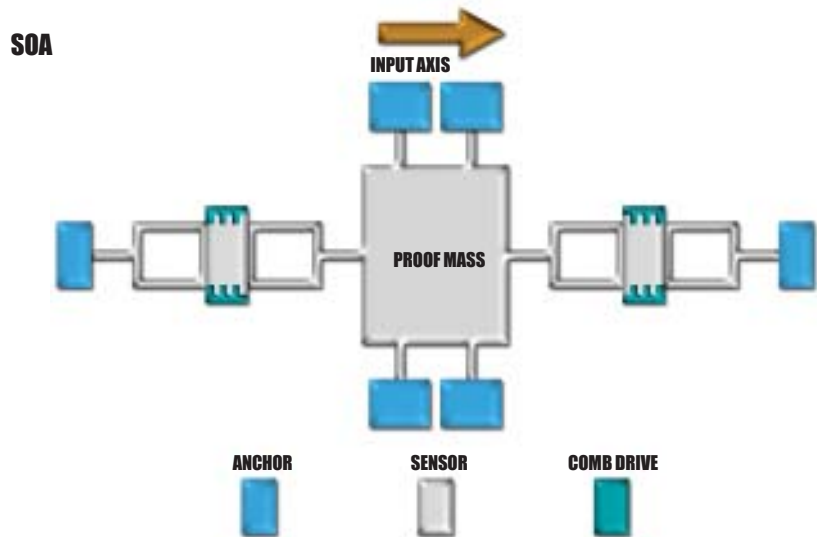

*Silicon Oscillating Accelerometer (SOA) Schematic*

## Silicon Oscillating Accelerometer

Draper Laboratory is in the process of developing the Silicon Oscillating Accelerometer (SOA), a revolutionary integration of microelectromechanical system (MEMS) sensor fabrication, packaging, and high performance electronics technologies that enables strategic-class performance from a miniature, low cost, high reliability solid-state accelerometer.

The SOA belongs to a general category of vibrating beam accelerometers (VBA),

The proof mass is also suspended above the substrate but is free to move in response to acceleration. When the device experiences acceleration, the proof mass pushes on one beam, putting it into compression, and pulls on the other beam, putting it into tension. This causes one beam's resonant frequency to increase while the other beam's frequency decreases. The difference in frequency can be sensed by readout electronics and is therefore related to the amount of acceleration seen by the device. The

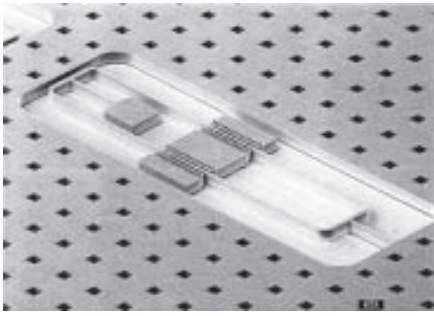

Close-up View of an SOA

image above shows a close-up of the vibrating beam (or tuning fork) structure of an SOA.

The SOA is packaged in a high reliability ceramic vacuum package to achieve high oscillator Q (quality factor) which is important for performance. The small size inherent in the MEMS technology, combined with low power (< 1 W) microelectronic circuitry, enables development of a small, high performance accelerometer suitable for emerging re-entry vehicle guidance applications, as well as the more conventional boost guidance ICBM/SLBM application. The MEMS sensor itself is small, only ½ cm on a side. However, this is considered a “large” MEMS device and requires special machining and fabrication processes.

Laboratory testing of breadboard SOAs has demonstrated an accelerometer dynamic range on the order of  $\pm 100$  g to  $1 \mu\text{g}$ , with a 1-sigma uncertainty in bias and scale factor of less than  $1 \mu\text{g}$  and 1 ppm respectively, which is considered strategic grade.

### Flexured Mass Accelerometer

The Draper Flexured Mass Accelerometer (FMA) is being developed for strategic missile guidance applications under the U.S. Air Force’s Guidance Applications Program (GAP). It utilizes solid-state technology; has low parts count, none moving or rubbing; and projects higher mean time between failure (MTBF) of about 600,000 hours and much lower acquisition and life-cycle costs than the FIGA, although it is about the same size.

The FMA is an open loop device that measures acceleration through an accurate and stable measurement of proof mass position. A schematic of the FMA below shows a proof mass with attached flexures placed in a main housing with cavity covers on each side.

The proof mass is supported by a set of ceramic flexure springs that allow proof mass deflection in response to acceleration. Microwave resonant cavities are attached to the two sides of the proof mass assembly. Measurement

of the proof mass displacement is accomplished with the two microwave resonant cavities differentially arranged to provide common mode error subtraction.

A microwave signal is applied to each sensor cavity through one coupler, and exited through a second. The cavities are driven into resonance by the microwave electronics. The volume of the cavity dictates its resonant frequency. Under acceleration, the flexured proof mass moves, making one cavity smaller and one cavity larger. Thus their natural frequencies shift either up or down. This change in frequency is sensed by readout electronics and is a direct measure of the device’s acceleration.

For missile guidance, proof mass displacement and trajectory acceleration must be measured accurately in the presence of high levels of shock, vibration, and radiation. Damping provided by a gas within the proof mass assembly limits its motion during shock and vibration to acceptable levels. The electronic components and circuit designs are either immune to the likely radiation environment or allow a sufficiently short recovery time so that the required navigational accuracy is assured.

The baseline FMA Engineering Model (EM-3) is shown below. Test data obtained on several FMAs are very promising. Weekend (three-day) bias stabilities of  $< 2 \mu\text{g}$  have been measured. The scale factor uncertainty appears better than 1 ppm. Thus the FMA performance goals for a strategic missile application appear within reach.

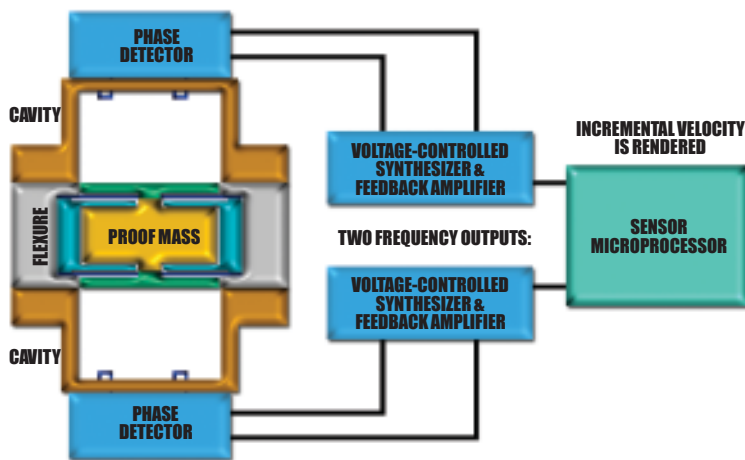

Flexured Mass Accelerometer (FMA) Schematic

FMA



FMA Engineering Model (EM-3)

# DRAPER LEADS MODERNIZING OF THE NAVY'S TRIDENT MK6 GUIDANCE SYSTEM

In late 2002, the U.S. Navy selected Draper Laboratory as the systems integrator to extend the service life of the Trident II (D5) missile's MK6 guidance system through the year 2042. This development effort provides an opportunity for Draper to modernize a 1980s system design through improved electronics, including a more flexible architecture, and new sensors, as well as to improve the overall effectiveness and supportability of the system through the remainder of its extended life cycle. The MK6 life extension (MK6LE) development effort will span the next 10 years and will involve the design efforts of many skilled engineers from Draper Laboratory and subcontractors across the country, including Raytheon, General Dynamics, DRC, Honeywell, and Northrop Grumman, among others.

The MK6 guidance system makes it possible for a submarine-launched ballistic missile to be guided, without human intervention, to a precise point in space above Earth's atmosphere. To accomplish this critical mission with the required accuracy, the MK6 system requires highly accurate sensors (accelerometers, gyros,



*Artist Rendering of Trident Submarine (courtesy of U.S. Navy)*

stellar) and computational precision. It must operate in extreme environments (heat, shock) and be able to survive and recover from a nuclear radiation event. For example, the system software and components must be able to detect the occurrence of a radiation event, enter a circumvention mode, recover, and restore all of the critical mission and guidance system variables needed to complete the mission.

The current MK6 design, although very complex and highly integrated, has achieved extraordinary reliability and accuracy performance levels. The strategy for the MK6LE is to ensure that these performance levels are maintained, but also to take advantage of modern electronic and digital processing technology to redesign the current highly integrated electronics architecture into a more modular system. This approach will enhance ease of operation, maintenance, repair, testability, and long-term supportability, as well as simplifying future upgrades. For example, with the new modular design a change from a spinning mass gyro to a solid-state gyro may affect only one subsystem electronics module instead of the dozen or more modules that would be affected in the existing MK6 design.

In addition, the MK6LE guidance system is a very software-intensive system. System software is required to implement critical mission requirements, as well as to

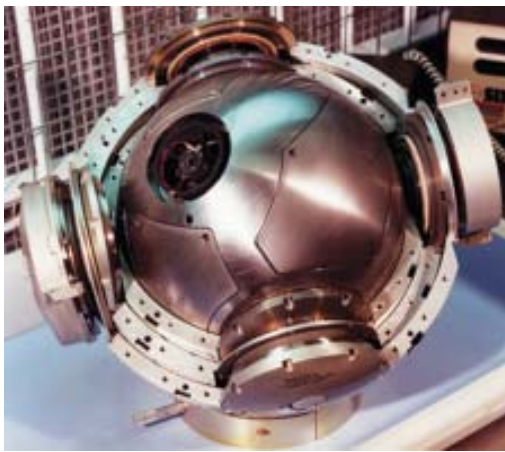

*MK6 Guidance System*

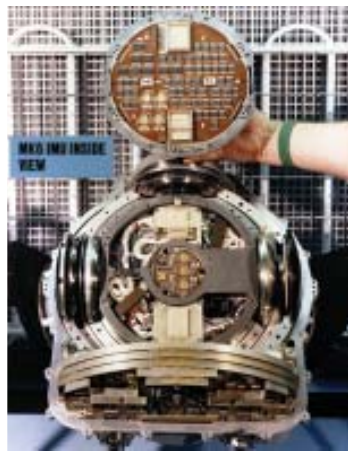

*MK6 Inside View*



Trident II Missile

support health and welfare monitoring, built-in self-test and test support, and non-resident downloadable test and diagnostic software. Since a major aspect of MK6LE is the upgrade of the computer memory and processors, the software also will require significant redesign. In the current design, limited processing capability required all software to be written in assembly language using a custom-built development environment. The new software strategy implements a new architecture which utilizes higher order languages (HOL) such as C, and leverages the use of commercial-off-the-shelf (COTS) development tools and commercially available processor technology, which will improve long-term supportability and enable a path for future software upgrades. MK6LE will be the first strategic guidance system to perform time- and event-sensitive circumvention and recovery of a strategic guidance system using HOL.

The MK6LE design will require the efforts of many individuals specializing in a wide range of technical disciplines, including physics, mechanical engineering, thermal analysis and metallurgy, radiation effects, application-specific integrated circuit (ASIC) design, electronics packaging, computer technologies, complex algorithm design, software

engineering, and other related disciplines. Focus areas for application of this expertise include critical replacement technologies, such as the development of accelerometers and gyros, radiation-hard parts, and computer memory and processors—each with its own set of challenges.

### The Role of Modeling and Simulation

A major MK6 life extension design strategy is to employ advanced modeling and simulation (M&S) techniques to help engineers develop and verify their designs and ensure performance requirements are satisfied in advance of hardware builds. The approach is intended to mitigate schedule and cost risks by uncovering and solving system performance issues early in the development phase.

To develop next-generation simulation environments for MK6LE, baseline versions of the MK6 system models are being assembled from dynamic behavioral models of the missile and other Trident subsystems to validate the guidance system's mission software well in advance of missile flight tests. The ultimate objective is to develop dynamic models for all MK6LE new designs and integrate them into a MK6LE virtual system simulation (VSim) based upon commercially available simulation tools. As the VSim control schemes mature, software and hardware developers will use the simulation to perform closed-loop testing of the designs. In conjunction with this, engineers will use simulations to perform validation and verification testing of the flight software as well as to develop test scenarios in advance of the availability of hardware.

State-of-the-art computer-aided design/computer-aided machining (CAD/CAM) design tools are being used in the electromechanical design area to create new system configurations and to predict critical responses of mechanical component designs. One new design required for MK6LE is the Stable Member (SM) and its electronics modules. This innermost part of

the guidance system houses the accelerometers, gyroscopes, stellar sensor, and a portion of the electronics. The SM requires precision tolerances to accurately mount the inertial instruments and stellar sensor as well as to ensure structural and thermal stability. CAD/CAM solid models are broken down further into finite element models (e.g., thermal, structural, temperature gradients, and deflected shape) for analysis to validate candidate designs before the final design is chosen and hardware is fabricated.

To attain M&S development efficiencies, Draper is continuing significant investment in COTS tools (such as MATLAB, SIMULINK, STATEFLOW, EASY5, ProENGINEER, ANSYS, and ModelSim) and integrating them in an environment of large multiprocessor computers with terabytes of storage to develop an integrated M&S framework. This infrastructure provides for configuration control, storage, and exchange of data and the ability to access development tools as well as to run distributed simulations, including real-time simulations. To ensure models can be integrated seamlessly, the M&S network is being developed using an Extensible Markup Language (XML) framework, an industry standard for data storage and exchange. XML defines a common layer for model integration, and as different

*(cont. on page 7)*



Trident Missile on Test Platform

# DESIGNING AN ENHANCED GROUND TEST CAPABILITY TO SIMULATE MISSILE TEST FLIGHTS

The truest measure of a strategic guidance system's reliability and accuracy performance can be obtained only by using actual flight tests, but these tests are infrequent and very expensive. For testing guidance systems, a simulation of missile and submarine environments that yields tactically representative performance estimates is a desirable option. Draper is developing such a simulation, the Enhanced Ground Test (EGT) capability, which will consist of a series of nondestructive tests.

Intended originally for testing the MK6 guidance system deployed in the U.S. Navy's Trident II (D5) missile to detect component aging issues, EGT also will be used to assess the performance of a MK6 guidance life extension (LE) design in advance of actual missile flight tests. EGT capability will reduce design risks by detecting performance issues earlier, and potentially it can reduce total reliance on actual tactical guidance hardware, missile flights, SSBN, and range costs. EGT will be adaptable to testing any guidance systems used in strategic, tactical, or space systems.

To develop the EGT operation baseline, telemetry data taken from actual missile flights were characterized to determine the dominant environments affecting system reliability and accuracy performance. These included acceleration (linear and angular), vibration, shock, and thermal profiles. Other environments characterized were magnetic, pressure, humidity, electrical, and radiation, which will be used for system design verification testing. Current testing has shown high fidelity by EGT in replication of the missile environments.

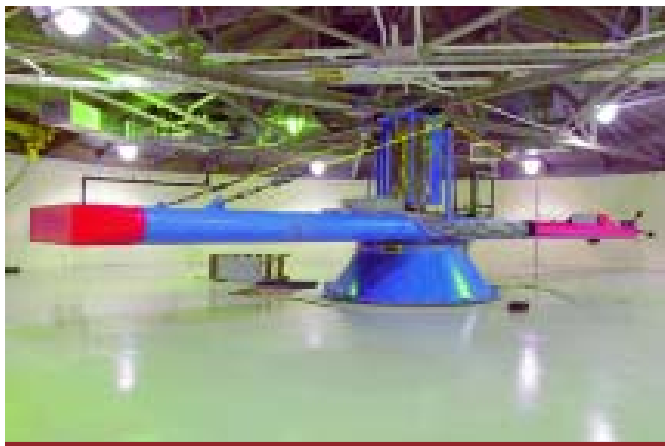

*The 32-ft. High-Precision Centrifuge Located in Bedford, Mass.*

## EGT's Concept of Operation

EGT will generate acceleration and low-level vibration environments by flying an aircraft pod instrumented with Global Positioning System/inertial navigation system equipment on an



*The Aircraft Pod Mounted on an F-15*

F-15 E aircraft. A ground-based, high-g dynamic shaker with thermal control provides the vibration, shock, and thermal environments.

After a guidance system is tested, the data will be analyzed for anomalies indicating failure. The data will pass through two filters – definite success and definite failure – before being mapped into a missile simulation to determine flight-equivalent success or flight-equivalent failure. To get an overall assessment of the deployed fleet population, results will be collected from multiple MK6 units.

Accuracy assessment is aided by a precision centrifuge with a 32-ft arm capable of spinning a 5,000-lb load at 40gs. Centrifuge testing provides increased observability of guidance system accuracy errors. The observability comes from high-g level testing over relatively long durations coupled with a precision measuring system (position error of less than 5 mils).

Data from the centrifuge will be combined with the other test data to estimate the guidance system contribution to the CEP (Circular Error Probable), a measure of the accuracy of the weapon system. This and results of several other tests will be combined to provide the overall CEP estimate.

## Timeframe for EGT

Use of EGT capability is planned throughout all phases of MK6 life extension system test, including design verification testing, initial performance assessment, follow-on assessment, and long-term surveillance. Development for EGT of a new aircraft pod, new vibration and shock capability, and advanced software analysis methods is progressing. EGT will be fully qualified and operational in GFY08, in time for design verification testing and initial assessment of the MK6LE guidance system.

## 2003 DISTINGUISHED PERFORMANCE AWARDS PRESENTED

The Distinguished Performance Awards (DPAs) recognize extraordinary and unique contributions by individuals and/or teams of Draper employees. The 2003 DPAs were presented to two teams by Chairman of the Board Dr. John Kreick (far left) and Vice President for Engineering Dr. Eli Gai (far right) at the Annual Dinner for Members of the Corporation on October 1. Each recipient was given a cash award and plaque.

Criteria for selection are that the work must demonstrate extraordinary performance by key individuals or a team that produces a major technical accomplishment on a challenging project of substantial benefit to the Lab and that is regarded as a major advance by the outside community. Nominations are reviewed by a committee of employees, who recommend their selections for the awards to senior management.



Tye Brady, Sean Buckley, Jeffrey Zinchuk, and William Wyman (not shown) received a team award for their work in the development and validation of the Inertial Stellar Compass (ISC) for Low Power Spacecraft Attitude Determination. The ISC is a miniature stellar-inertial attitude sensor and represents the first use of microelectromechanical sensors for space attitude determination. It will support the construction of a new generation of micro-satellites.



For the development and application of Multichip Module-D (MCM-D) High Density Interconnect Packaging, Mark Singleton, Caroline Kondoleon, Dariusz Pryputniewicz, and Jason Haley received a team award. The MCM-D High Density Interconnect Packaging is a new method for producing small, ultra-dense electronic devices. Their work demonstrated a commanding lead over competition in high density multichip module technology.

*(cont. from page 5)*

modeling tools/languages/standards emerge only a single bridge needs to be built to integrate the respective model types.

These simulations will be accessible at the desktop by engineers at Draper and major team members around the country for collaborative design efforts via a secure virtual private network. This distributed M&S infrastructure will allow the design community to create numerous virtual prototypes of the system throughout development. In effect, these simulation techniques allow system integration to start during the design phase.

### **Building Electronics for the Strategic Environment**

One major challenge for the MK6LE team is to develop electronics for a strategic computer that is required to be radiation-hard and maintainable for 30 years while

commercial computer technology and tools turn over annually. To complicate the challenge, strategic computer designs must be made available years in advance of actual production, during which time semiconductor foundries will be changing their processes.

To solve this problem of technology turnover, Draper is capturing its digital ASIC designs in Hardware Design Language (HDL) with special care to avoid foundry-specific implementations. This design methodology should allow porting to alternate foundry facilities without extensive redesign – much like software design in a high level language allows the code to be “portable.”

In the area of computer processor designs, dealing with technology turnover and obsolescence has an added complexity. A custom, proprietary-designed, HDL

processor faces the same obsolescence issues as those of COTS processors and their associated tools and support, but a custom design also has significant costs of tool development and support as well as a very small user base, which can lead to faults being undetected until late in the life cycle. To mitigate these issues, a strategy of using commercially available intellectual property (IP) cores is being developed.

An IP core provides HDL for a processor and other functions which can be synthesized and targeted for a wide selection of foundries. Since the core is commercially available, it has a large customer base, leading to early detection and correction of defects. Obsolescence issues are avoided because the design is captured in HDL, and the tools are delivered from the vendor and can be

*(cont. on page 8)*

## BOARD AND CORPORATION GAIN NEW MEMBERS

At the Annual Meeting of the Draper Corporation, held October 1, 2003, one new member was elected to the Board of Directors and two new members were elected to the Corporation. The new Director is Peter Read; the new Members of the Corporation are Robert Brown and John Parrish.



**Peter Read**, a Member of the Corporation since 1981, previously served on Draper's Board from 1983 to 1996. Read has been a consultant since 1992, when he concluded his career at The First National Bank of Boston as executive vice president. Read has a bachelor's degree from Middlebury College in political science and a master's in business administration from Stanford University. Read is a director of American Student Assistance Corp. and of Data Integrity Inc., and he is a member of the advisory council of the Program in International Business Relations of The Fletcher School of Law and Diplomacy.



**Robert Brown** is the provost and Warren K. Lewis Professor of Chemical Engineering at the Massachusetts Institute of Technology (MIT). He joined MIT's faculty in 1979 after he received his doctorate in chemical engineering from the University of Minnesota;

Brown's bachelor's and master's degrees in chemical engineering are from the University of Texas at Austin. As one of his responsibilities, Brown oversees Lincoln Laboratory. He is a member of the National Academy of Engineering, the American Academy of Arts and Sciences, and the National Academy of Science, and he serves on several national advisory boards.



**John Parrish** is the chairman of the Department of Dermatology at Harvard Medical School (HMS), chief of the Dermatology Service at Massachusetts General Hospital (MGH), and professor of Health Science and Technology at MIT. He directs the Wellman Laboratories of Photomedicine at MGH. Parrish is also a director of the Center for the Integration of Medicine and Innovative Technology, a consortium of which Draper Laboratory is a member. Parrish received a bachelor's degree in political science from Duke University and his medical degree from Yale University School of Medicine.

*(cont. from page 7)*

archived for the project. Many IP cores are configurable, allowing them to be customized for each implementation.

In the area of memory, current strategic computers rely on two types: nonvolatile memory, which retains data even if power is off, and volatile memory, which does not. Strategic computers typically require three memory functions: a nonvolatile read-only memory to store the program that executes the mission, a nonvolatile read/write memory to store critical variables that are generated during the mission, and a volatile memory to assist with high-speed calculations during the mission.

For nonvolatile read/write memory, all past strategic system computers used a proprietary, bulky, plated-wire memory technology. MK6LE has memory needs similar to those of past systems, but plated wire is no longer available or desirable. Developing a new proprietary memory for

life extension is cost-prohibitive. Therefore, the development team is evaluating commercial memory technologies that potentially can be packaged for strategic applications. Competing for use in commercial PDAs, laptop computers, and cell phones, the candidate technologies being evaluated are based on ferroelectric, magnetoresistive and chalcogenide phase-change (now used in DVDs) materials.

### Timeframe

Draper, and its contractor team members, already have staffed the key positions for the LE program by searching across the organizations to find the very best individuals. Many have significant Trident experience, while some have been assigned as leaders who have proven their ability in other complex design programs. The team successfully

completed the System Architecture Review in September 2003. The Preliminary System Design Review is scheduled for 2005, the Critical Design Review for 2007, and Initial Operational Capability in 2013.

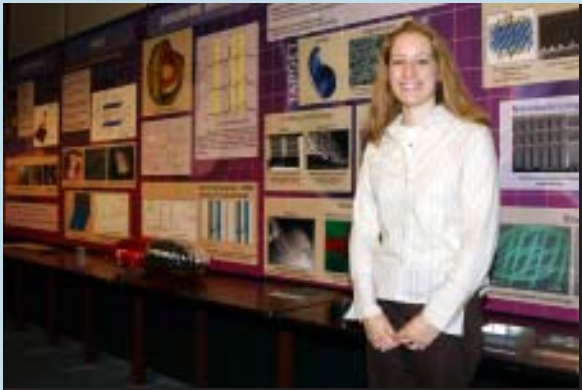

Photo Courtesy of U.S. Navy

Trident II D5 Missile Launch



# TECHNOLOGY EXPOSITION 2003 SHOWS STRENGTH, BREADTH



Draper Laboratory's 2003 Technology Exposition, held October 1 and 2, showcased recent projects. In addition to employees and Corporation members, the Expo welcomed students from local universities and Cambridge's public high school, as well as journalists and sponsors.

Attendees saw exhibits featuring technologies under development at Draper from across the Laboratory's program areas, including strategic, tactical, space systems, special operations, biomedical engineering, and independent research and development. A number of the projects included graduate or undergraduate students on their teams, whose participation is coordinated through Draper's Education Office.



The projects exhibited embodied the Laboratory's core competencies: guidance, navigation, and control; embedded, real-time software; microelectronics and packaging; autonomous systems; distributed systems; microelectromechanical systems; biomedical engineering; and prototyping system solutions.

Draper's subsidiary venture capital fund, Navigator Technology Ventures, LLC (NTV), displayed information about its portfolio companies, Sionex Corp., Sand Video, Actuality Systems, Polychromix, Aircuity, and PLEJ Inc., at the Expo. Local venture capitalists invited by NTV toured the Expo to see the types of technologies produced at Draper and potentially available for licensing through Draper's Technology Licensing Office.



*From top to bottom:*

1. Aeronautical engineer Linda Fuhrman is poised to discuss the features of ARES, a proposed Mars scout mission designed to perform an aerial survey of Mars
2. Draper engineer Melissa Krebs stands ready to answer questions about the Lab's biomedical engineering projects
3. Students from Cambridge Rindge and Latin School view exhibits from NTV's portfolio companies
4. Program Manager Rob Larsen demonstrates Draper's High Mobility Tactical Micro Robot to Board Members Maxine Savitz and Delores Etter



The Charles Stark Draper Laboratory, Inc.  
555 Technology Square  
Cambridge, MA 02139-3563

Return Service Requested

Headquarters:

The Charles Stark Draper Laboratory, Inc.  
555 Technology Square  
Cambridge, MA 02139-3563  
Telephone: (617) 258-1000  
Facsimile: (617) 258-1131

E-mail: [communications@draper.com](mailto:communications@draper.com)  
[www.draper.com](http://www.draper.com)

Business Development

Telephone: (617) 258-2124  
[busdev@draper.com](mailto:busdev@draper.com)

Washington Area Offices:

Suite 501  
1555 Wilson Boulevard  
Arlington, VA 22209  
Telephone: (703) 243-2600